

TOWABLE BOOM LIFTS

XYZLIFT
REACH YOUR EXTREME LIMITS



Jinan XYZTech Machinery Co.,Ltd.

Tel.+ 86 18366130656 | info@xyzlift.com



TOWABLE BOOM LIFTS

Model **XYZTBL-10**

Measurements	Metric	US
Platform height	10m	32 ft 9.7 in
Max working height	12m	39ft4.4in
Horizontal reach	5.5m	18ft 0.5 in
A Platform length	0.7m	2ft 3.6 in
B Platform width	0.9m	2ft 11.4 in
C Height - stowed	2.1m	6ft 10.7 in
D Length- stowed	6.3m	20 ft 8 in
E Width- stowed	1.7m	5ft 6.9 in
F Ground clearance	0.25m	9.8in
G Length-outrigger footprint	3.9m	12 ft 9.5 in
H Width-outrigger footprint	3.9m	12 ft 9.5 in

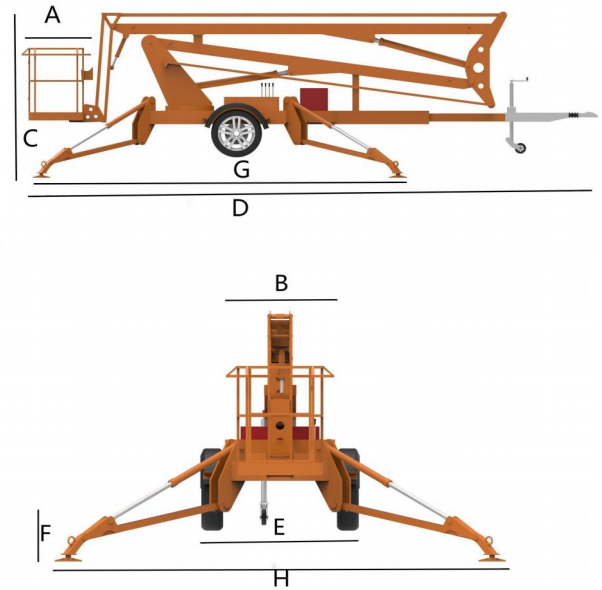

Productivity

Lift capacity-Standard	200kg	400lb
Turntable rotation	360°	360°
Self leveling platform	3°	3°
Max towing speed	100km/h	62mph
Tire size	Rubber tyre 700mm	
Weight	1950kgs	4300lb

*Machine weights may increase with options

Power

Single energy

- AC Power only -Standard
- 24V DC Batteries only
- Diesel engine only
- Petrol engine only

Bi-energy(Optional)

- AC+Diesel engine
- AC+petrol engine
- AC+battery
- Battery+Diesel
- Battery+Petrol

Reach Dimensions

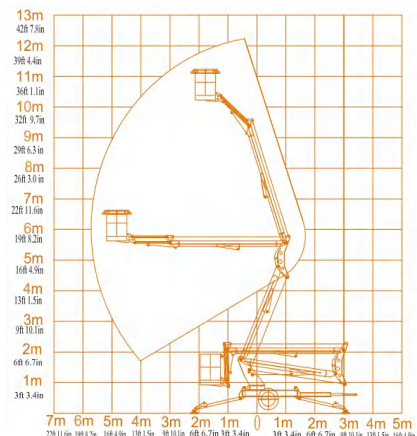

For Special size or heavy load capacity boom lift, please contact us info@xyzlift.com



TOWABLE BOOM LIFTS

Model **XYZTBL-12-1**

Measurements	Metric	US
Platform height	12m	39 ft 4.4 in
Max working height	14m	45ft11.2in
Horizontal reach	6.5m	21ft 3.9 in
A Platform length	0.7m	2ft 3.6 in
B Platform width	0.9m	2ft 11.4 in
C Height - stowed	2.1m	6ft 10.7 in
D Length- stowed	7.3m	23 ft 11.4 in
E Width- stowed	1.7m	5ft 6.9 in
F Ground clearance	0.25m	9.8in
G Length-outrigger footprint	3.9m	12 ft 9.5 in
H Width-outrigger footprint	3.9m	12 ft 9.5 in

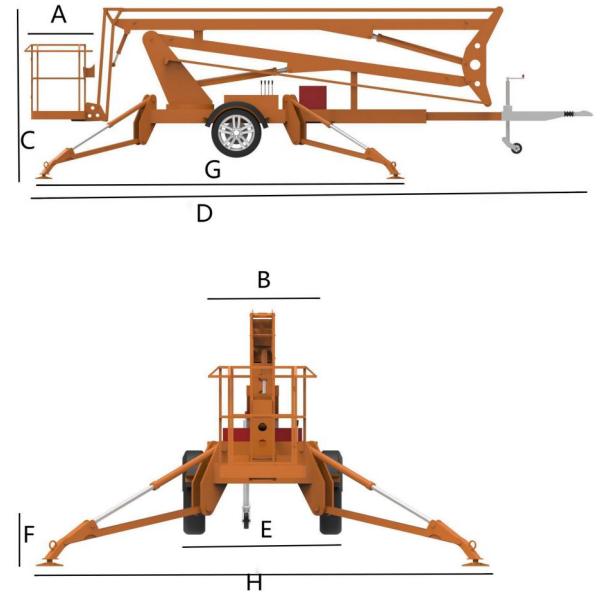

Productivity

Lift capacity-Standard	200kg	400lb
Turntable rotation	360°	360°
Self leveling platform	3°	3°
Max towing speed	100km/h	62mph
Tire size	Rubber tyre 700mm	
Weight	2100kgs	4300lb

*Machine weights may increase with options

Power

Single energy

- AC Power only -Standard
- 24V DC Batteries only
- Diesel engine only
- Petrol engine only

Bi-energy(Optional)

- AC+Diesel engine
- AC+petrol engine
- AC+battery
- Battery+Diesel
- Battery+Petrol

Reach Dimensions

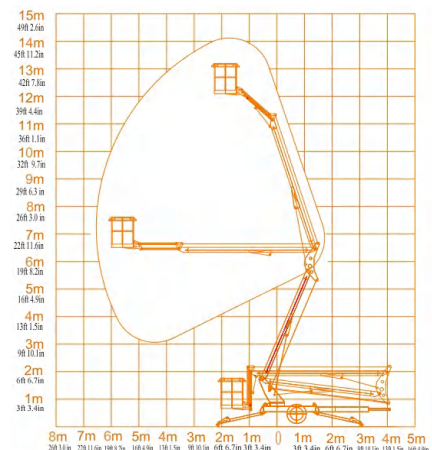

For Special size or heavy load capacity boom lift, please contact us info@xyzlift.com



TOWABLE BOOM LIFTS

Model **XYZTBL-12-2**

Measurements	Metric	US
Platform height	12m	39 ft 4.4 in
Max working height	14m	45ft11.2in
Horizontal reach	6.5m	21ft 3.9 in
A Platform length	0.7m	2ft 3.6 in
B Platform width	0.9m	2ft 11.4 in
C Height - stowed	2.1m	6ft 10.7 in
D Length- stowed	5.8m	19 ft 0.3 in
E Width- stowed	1.7m	5ft 6.9 in
F Ground clearance	0.25m	9.8in
G Length-outrigger footprint	3.9m	12 ft 9.5 in
H Width-outrigger footprint	3.9m	12 ft 9.5 in

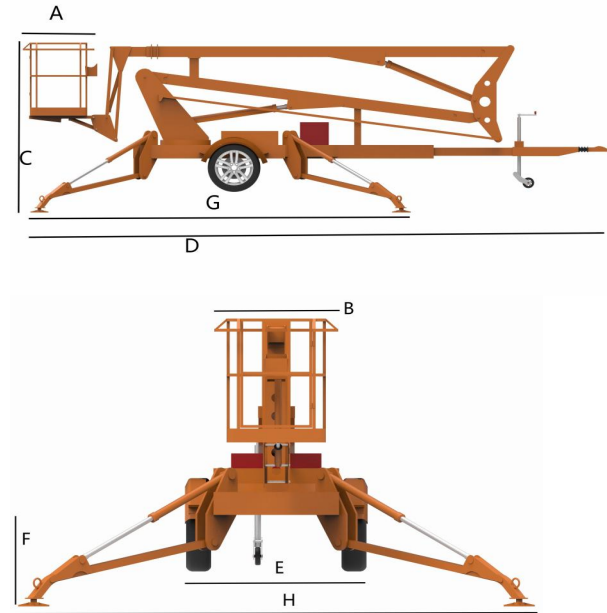

Productivity

Lift capacity-Standard	200kg	400lb
Turntable rotation	360°	360°
Self leveling platform	3°	3°
Max towing speed	100km/h	62mph
Tire size	Rubber tyre 700mm	
Weight	2100kgs	4300lb

*Machine weights may increase with options

Power

Single energy

- AC Power only -Standard
- 24V DC Batteries only
- Diesel engine only
- Petrol engine only

Bi-energy(Optional)

- AC+Diesel engine
- AC+petrol engine
- AC+battery
- Battery+Diesel
- Battery+Petrol

Reach Dimensions

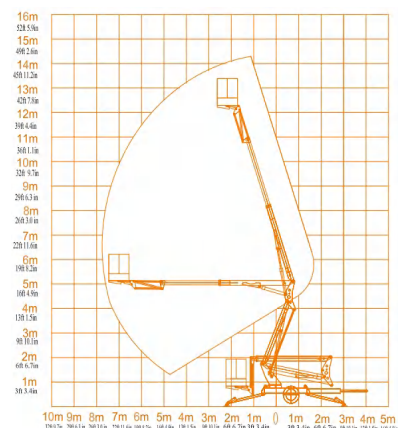

For Special size or heavy load capacity boom lift, please contact us info@xyzlift.com



TOWABLE BOOM LIFTS

Model **XYZTBL-14**

Measurements	Metric	US
Platform height	14m	45 ft 11.2 in
Max working height	16m	52ft5.9in
Horizontal reach	8.5m	27ft 10.6 in
A Platform length	0.7m	2ft 3.6 in
B Platform width	0.9m	2ft 11.4 in
C Height - stowed	2.1m	6ft 10.7 in
D Length- stowed	6.65m	21 ft 9.8 in
E Width- stowed	1.7m	5ft 6.9 in
F Ground clearance	0.25m	9.8in
G Length-outrigger footprint	3.9m	12 ft 9.5 in
H Width-outrigger footprint	3.9m	12 ft 9.5 in

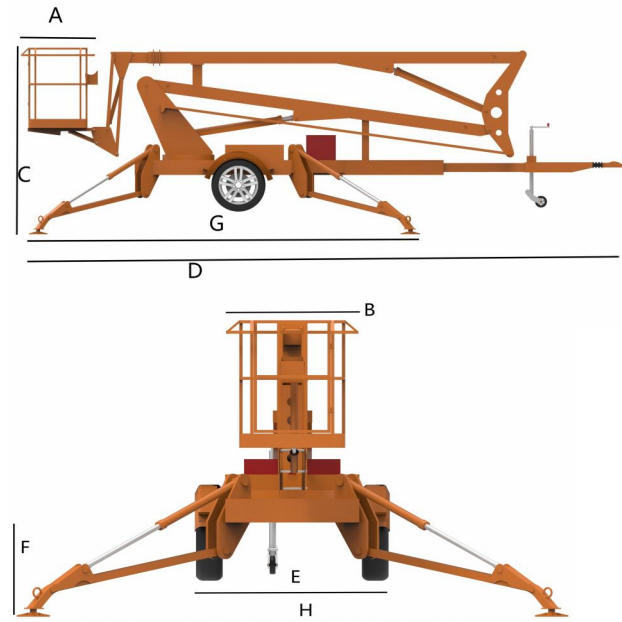

Productivity

Lift capacity-Standard	200kg	400lb
Turntable rotation	360°	360°
Self leveling platform	3°	3°
Max towing speed	100km/h	62mph
Tire size	Rubber tyre 700mm	
Weight	2250kgs	4300lb

*Machine weights may increase with options

Power

Single energy

- AC Power only -Standard
- 24V DC Batteries only
- Diesel engine only
- Petrol engine only

Bi-energy(Optional)

- AC+Diesel engine
- AC+petrol engine
- AC+battery
- Battery+Diesel
- Battery+Petrol

Reach Dimensions

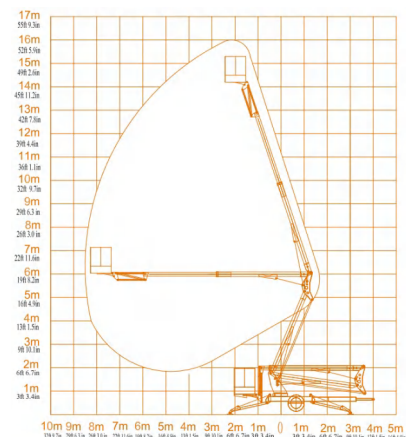

For Special size or heavy load capacity boom lift, please contact us info@xyzlift.com



TOWABLE BOOM LIFTS

Model **XYZTBL-16**

Measurements	Metric	US
Platform height	16m	52 ft 5.9 in
Max working height	18m	59ft0.7in
Horizontal reach	10.5m	34ft 5.4 in
A Platform length	0.7m	2ft 3.6 in
B Platform width	0.9m	2ft 11.4 in
C Height - stowed	2.25m	7ft 4.6 in
D Length- stowed	6.8m	22 ft 3.7 in
E Width- stowed	1.7m	5ft 6.9 in
F Ground clearance	0.25m	9.8in
G Length-outrigger footprint	4.1m	13 ft 5.4 in
H Width-outrigger footprint	4.1m	13 ft 5.4 in

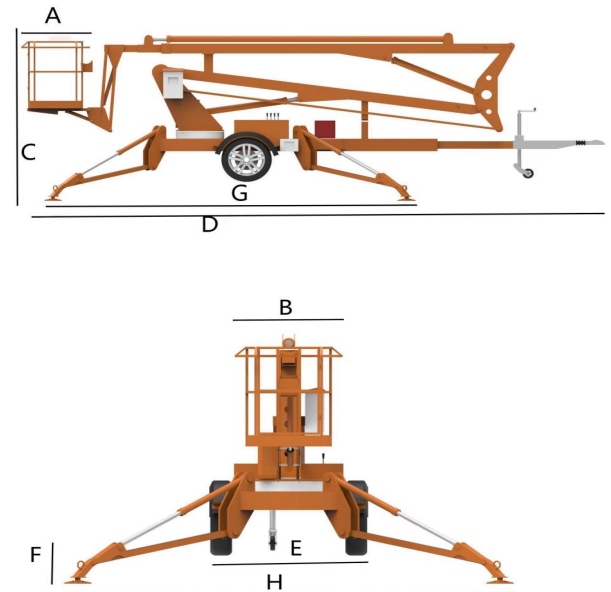

Productivity

Lift capacity-Standard	200kg	400lb
Turntable rotation	360°	360°
Self leveling platform	3°	3°
Max towing speed	100km/h	62mph
Tire size	Rubber tyre 700mm	
Weight	2350kgs	4300lb

*Machine weights may increase with options

Power

Single energy

- AC Power only -Standard
- 24V DC Batteries only
- Diesel engine only
- Petrol engine only

Bi-energy(Optional)

- AC+Diesel engine
- AC+petrol engine
- AC+battery
- Battery+Diesel
- Battery+Petrol

Reach Dimensions

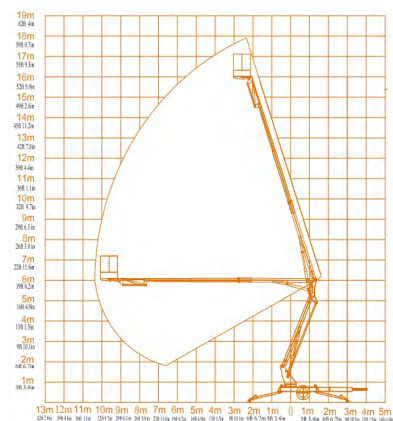

For Special size or heavy load capacity boom lift, please contact us info@xyzlift.com



TOWABLE BOOM LIFTS

Model **XYZTBL-18**

Measurements	Metric	US
Platform height	18m	52 ft 5.9 in
Max working height	20m	59ft 0.7in
Horizontal reach	11m	36ft 1.1 in
A Platform length	0.7m	2ft 3.6 in
B Platform width	0.9m	2ft 11.4 in
C Height - stowed	2.25m	7ft 4.6 in
D Length- stowed	7.6m	24 ft 11.2 in
E Width- stowed	1.8m	5ft 10.9 in
F Ground clearance	0.25m	9.8in
G Length-outrigger footprint	6.5m	21 ft 3.9 in
H Width-outrigger footprint	6m	19 ft 8.2 in

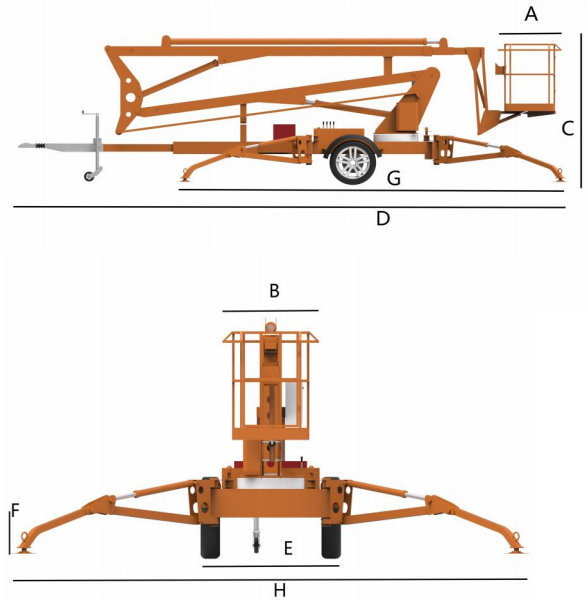

Productivity

Lift capacity-Standard	200kg	400lb
Turntable rotation	360°	360°
Self leveling platform	3°	3°
Max towing speed	100km/h	62mph
Tire size	Rubber tyre 700mm	
Weight	3600kgs	4300lb

*Machine weights may increase with options

Power

Single energy

- AC Power only -Standard
- 24V DC Batteries only
- Diesel engine only
- Petrol engine only

Bi-energy(Optional)

- AC+Diesel engine
- AC+petrol engine
- AC+battery
- Battery+Diesel
- Battery+Petrol

Reach Dimensions

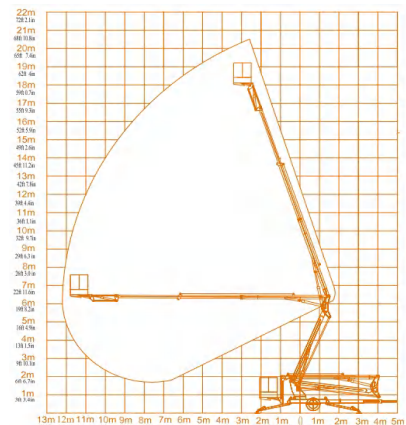

For Special size or heavy load capacity boom lift, please contact us info@xyzlift.com



TOWABLE BOOM LIFTS

Model **XYZTBL-20**

Measurements	Metric	US
Platform height	20m	65ft 7.4 in
Max working height	22m	72ft 2.1 in
Horizontal reach	11m	36ft 1.1 in
A Platform length	0.7m	2ft 3.6 in
B Platform width	0.9m	2ft 11.4 in
C Height - stowed	2.25m	7ft 4.6 in
D Length- stowed	6.9m	22 ft 7.7 in
E Width- stowed	1.8m	5ft 10.9 in
F Ground clearance	0.25m	9.8in
G Length-outrigger footprint	6.5m	21 ft 3.9 in
H Width-outrigger footprint	6m	19 ft 8.2 in

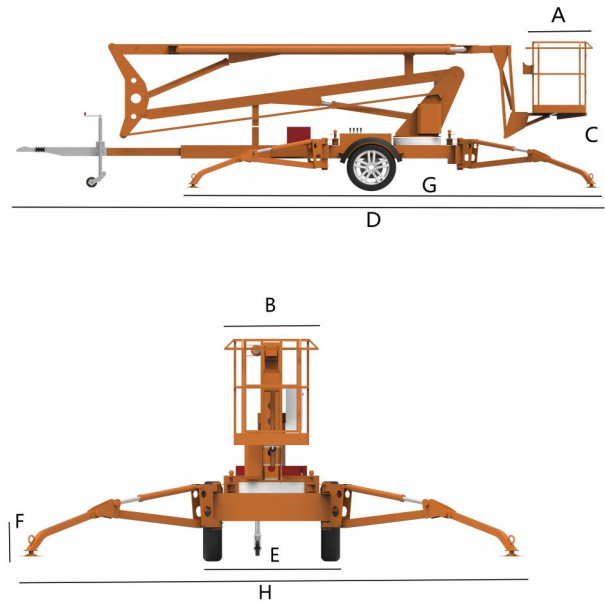

Productivity

Lift capacity-Standard	200kg	400lb
Turntable rotation	360°	360°
Self leveling platform	3°	3°
Max towing speed	100km/h	62mph
Tire size	Rubber tyre 700mm	
Weight	4500kgs	4300lb

*Machine weights may increase with options

Power

Single energy

- AC Power only -Standard
- 24V DC Batteries only
- Diesel engine only
- Petrol engine only

Bi-energy(Optional)

- AC+Diesel engine
- AC+petrol engine
- AC+battery
- Battery+Diesel
- Battery+Petrol

Reach Dimensions

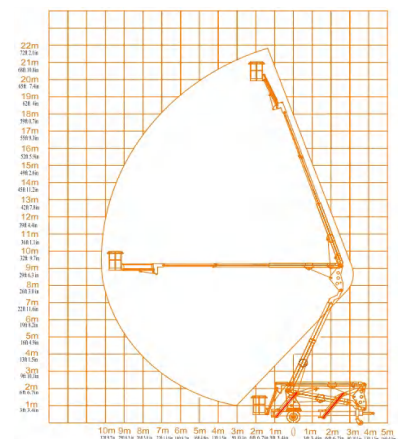

For Special size or heavy load capacity boom lift, please contact us info@xyzlift.com



Standard equipment

- Platform with light
- Overload protection
- Hydraulic outriggers with interlocks
- Torsion shaft ensure lift move stable by towing
- Easily towed & manoeuvred on site
- Parking brake
- Tool tray
- Controller on platform and ground
- Illuminated outrigger indicators
- Proportional Hydraulic Controls
- Inertia brake
- Electromagnetic brake
- Auxiliary platform descent
- Highway safety chains with snap lock
- Safety valve prevent lift down if oil pipe leak oil
- Tilt Alarm sensor/ Indicator Light
- Variable speed control system
- Flashing beacon

Option

- Traction drive
- Forklift pockets
- AC power to platform
- Hour meter
- Spare tire
- Auto-Leveling Hydra

 **Jinan XYZTech Machinery Co.,Ltd.**
 No.15 Jiyang Industrial Park, Jinan, China
 86 18366130656
 info@xyzlift.com
 www.xyzawp.com

Warranty

We provide a 5-year warranty on the operational parts of the lift and a 1-year warranty on the electronic components. In case of any defect during the warranty, the company is responsible for free exchanges. Due to continuous product improvements, we reserve the right to make specification and/or equipment changes without prior notification.



SafeWork NSW

